

3.2 寸显示屏

3.2-inch display screen

LCD-3.2-RS485

使用维护说明书

Operation and maintenance manual

成都极空科技有限公司

**Chengdu Jikong technology co., LTD**

1. 产品简介(PRODUCT INTRODUCTION).....	3
2. 显示屏外观(DISPLAY APPEARANCE).....	3
3. 接口与线缆(INTERFACE AND CABLES).....	3
4. 接线方式(CONNECTION DIAGRAM).....	4
5. 产品尺寸图(PRODUCT DIMENSION DRAWING).....	5
6. 显示内容说明(DISPLAY DESCRIPTION).....	5
7. 显示屏亮灭逻辑(DISPLAY ON/OFF LOGIC).....	6

## 1. 产品简介(Product Introduction)

本产品为一款 3.2 英寸 LCD 显示屏，专为配套我司锂电池保护板使用而设计。可实时显示电池的电压、电流、电量（SOC）以及报警状态等关键信息，界面清晰直观。

This product is a 3.2-inch LCD display, specifically designed to be used with our company's lithium battery protection boards. It can display key information such as the battery's voltage, current, state of charge (SOC), and alarm status in real-time, with a clear and intuitive interface.

显示屏支持 RS485 通信方式。供电电压范围为 9V 至 12V，适配多种电池供电系统。

The display supports RS485 communication. Its power supply voltage range is 9V to 12V, making it compatible with various battery-powered systems.

该显示屏外观小巧，色彩鲜明，适用于电动车、储能系统等对电池状态有可视化需求的场景，具备高可靠性和易用性。

With its compact design and vibrant interface, this display is ideal for electric vehicles, energy storage systems, and other applications requiring reliable and intuitive battery status monitoring.

## 2. 显示屏外观(Display appearance)



## 3. 接口与线缆(Interface and cables)

线缆总长 0.7M





接口定义/Interface definition

连接器 Connector	序号	说明
用户接口 User Interface GH1.25-6P	1	K-
	2	K+
	3	GND
	4	RS485-B
	5	RS485-A
	6	VCC, 接 12V 供电 Connect to 12V power supply

#### 4. 接线方式(Connection diagram)

将配线一端接显示屏的用户接口，另一端接保护板的显示屏接口即可，无需分辨方向。

Simply connect one end of the wiring to the user interface of the display screen and the other end to the display interface of the protection board; there is no need to distinguish the direction.

## 5. 产品尺寸图(Product dimension drawing)

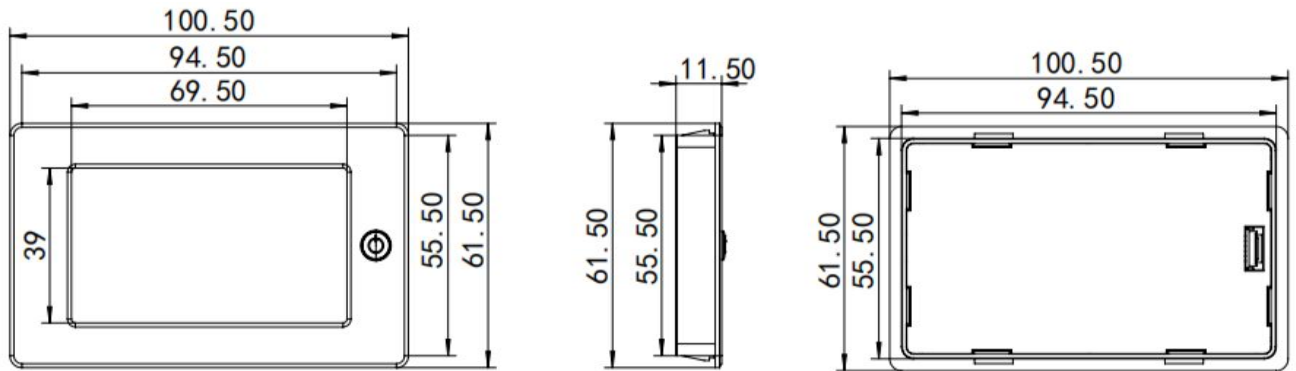

## 6. 显示内容说明(Display description)

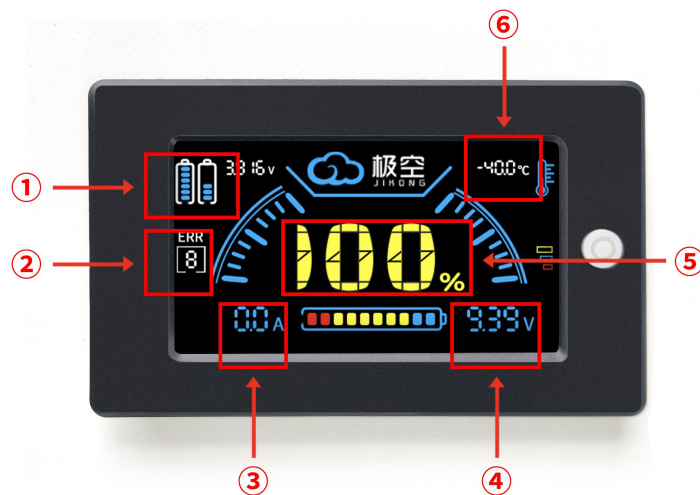

区域 1: 平均电压显示区域

Area 1: Average voltage display area.

区域 2: 故障代码显示区域, 当该图标亮起时, 下方显示的数字为故障代码, 当前显示故障代码为 8, 如有多个故障信息, 则会滚动显示, 故障代码对照表如下表所示。

Area 2: Fault code display area. When the icon is lit, the number displayed below is the fault code. The current fault code displayed is 8. If there are multiple fault messages, they will be displayed in a scrolling manner. The fault code comparison table is as shown below.

故障代码 Fault code	报警内容 Alarm description	故障代码 Fault code	报警内容 Alarm description
1	单体过放报警 Single cell undervoltage alarm	6	短路报警 Short circuit alarm
2	单体过充报警 Single cell overvoltage alarm	7	内部通讯异常报警 Internal communication failure

			alarm
3	过流报警 Overcurrent alarm	8	均衡线电阻过大报警 Balancing line resistance too high alarm
4	MOS 过温报警 MOS overtemperature alarm	9	掉串 Cell string loss
5	电池过温报警 Battery overtemperature alarm		

区域 3: 充放电电流显示区域, 最左边“-”表示电流为负值, 此时显示值放电电流; 若没有“-”, 电流显示为正值, 此时显示电流为充电电流。

Area 3: Charging and discharging current display area. The "-" on the far left indicates that the current is negative, and the displayed value is the discharging current; if there is no "-", the current is displayed as a positive value, which is the charging current.

区域 4: 电池总电压显示区域。

Area 4: Total battery voltage display area.

区域 5: 电量显示区域

Area 5: Battery level (SOC) display area.

区域 6: 电池温度显示区域

Area 6: Battery temperature display area.

## 7. 显示屏亮灭逻辑(Display on/off logic)

为了降低功耗, 特定义以下逻辑:

In order to reduce power consumption, the following logic is specified:

- 静态: 无充/放电电流、未操作按键, 35 秒后自动灭屏;
- Static: no charge/discharge current, no operation button, 35 seconds after the screen automatically off;
- 放电: 当电流大于 0 时, 显示屏常亮;
- charge/discharge: When the current is greater than 0, the display is steady on.
- 按键: 静态下屏幕熄灭后, 按一下按键又会亮屏 35S。
- Button: After the screen is off in static mode, the screen will light up for 35S after you press the button.